

Fault Detection and Diagnosis of 3-Phase Inverter System

M. S. Khanniche and M. R. Mamat-Ibrahim

University of Wales, Swansea, United Kingdom.

Abstract – *This paper describes a method of detection and identification of transistor base drive open-circuit fault of 3-phase voltage source inverter (VSI), feeding a fuzzy logic controlled induction motor. The detection mechanism is based on a novel technique of wavelet transform. In this method, the stator currents will be used as an input to the system. No direct access to the induction motor is required. The detection mechanisms have been rigorously examined theoretically and experimentally, and it has been shown that the developed system is robust and reliable.*

Résumé – *Cet article décrit une technique d'identification et de détection d'une panne à la base d'un transistor, qui compose le convertisseur d'une source de tension triphasée, ce dernier alimente un moteur à induction contrôlé par une logique floue. Le mécanisme de détection est basé sur le principe de la transformée en ondelette. Dans cette méthode, le courant issue du stator sert d'entrée au système, ainsi, l'accès au moteur à induction n'est pas nécessaire. Les performances du système développé ont été mises en évidence par une étude théorique et une étude pratique.*

Keywords: Detection – Identification – Fault – Induction motor – Stator – Wavelet transform.

1. INTRODUCTION

The increase of productivity requirements and better performance specifications lead to more demanding operating condition of many engineering systems. Such condition will increase the possibility of the system failure, which are characterised by critical and unpredictable changes in the system dynamics. In general, feedback control algorithm, which is designed to control small perturbation that may arise under normal operating condition, cannot accommodate abnormal behaviour due to the components fault. The system may collapse completely.

Most of the power electronic devices normally operate in an environment requiring rapid speed variation, frequent stop / starting and constant overloading. The circuits are subject to constant abuse of over-current surge and voltage overshoots. Although protection devices such as snubber circuits are commonly used, switching devices are physically small and thermally fragile. Even a small electrical disturbance can cause thermal rating to be exceeded resulting in rapid destruction. In many cases, occasional failures may be tolerated, but, in the case of expensive, high power systems, multi-converter integrated automation systems and safety critical systems, advanced indication of unusual performance which may lead to sudden system failure is mandatory.

Therefore, the knowledge and information about the fault behaviour of power electronic circuits is important to improve system design, protection and fault tolerant control. Unfortunately, condition monitoring of the power electronic systems only received a little attention compared with fault diagnostics of motor [1-3]

An early study was made by Renfrew and Tian [4], who have investigated detection of converter faults by using the simplest criteria available in input and output waveform. The value of DC component in current and voltage was used as main factor to detect the faults. Then the knowledge-based system was used to analyse the results.

Aris *et.al* [5] used digital signal processing and knowledge based approach to detect and analyse all possible faults in inverter circuit. The fuzzy logic techniques was used and utilised. The implementation of the fault detection knowledge base was successfully demonstrated by interfacing it with the power electronics design tool package run on SUN workstation.

Also in 1994, Kastha and Bose [6] have investigated the various fault modes of a PWM voltage source inverter system for induction motor. The important fault types are identified. The predicted faults performances are then substantiated by simulation study. The study has been used to determine stresses in power circuit components and to evaluate satisfactory post – fault steady-state operating region.

Recently, Mendes *et.al* [7] presented a Park's vector approach on detecting and diagnosing the inverter fault. The laboratory prototype was built to prove this technique. They reported success to detect and identify the occurrence of single faults like an open circuit or short circuit of transistor.

However, only a study of an open loop volt/Hz speed control strategy of an induction motor have been done as reported in the literature above. This paper presents experimental results on condition monitoring and fault detection of transistor base drive open-circuit faults of a 3-phase voltage source inverter (VSI), fuzzy controlled induction motor. The fault detection algorithm is based on a novel technique of wavelet transform of stator

currents. The ability to perform a set of analysis such as transient and local analysis is one of the most interesting features of this technique.

2. INVERTER TRANSISTOR BASE DRIVE OPEN-CIRCUIT FAULT

A PWM-VSI inverter induction motor drive system is shown in figure 1. In this paper, only a single transistor base drives open-circuit fault of power converter will be considered. This fault will only reduce the operating conditions of the drive without involving the short circuit protection of the system. The drive system can operate for a considerable period of time but with degraded performance and low efficiency. The injected dc offset in the machine phase currents caused by a base drive open-circuit fault, worsen the current stress of the inverter healthy switching devices. Continuous operation in such faulty condition may lead to the catastrophic breakdown of the drive system.

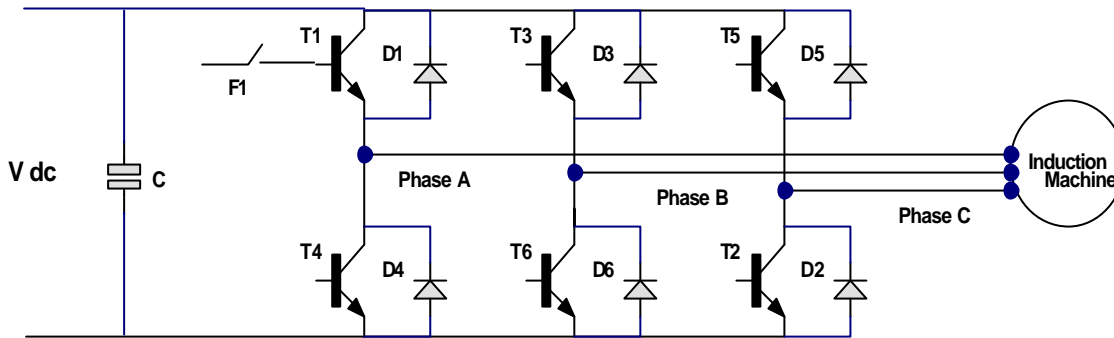

Fig. 1: A PWM voltage-fed inverter of induction motor drive

To operate power transistors such as MOSFET or IGBT, an appropriate gate voltage must be applied in order to drive transistors into the saturation mode for low on-state voltage. Malfunctioning of gate drive circuit can lead to the transistor base drive open-circuit fault.

Since the transistor T1 has now an open-circuit fault (F1), the phase A of the induction machine is connected to the positive dc rail through the diode D1. The machine phase A voltage is then determined by the polarity of current and the switching pattern of transistor T4. The phase voltage (V_A) will be clamped to the negative rail if stator current phase A, (i_A) is positive. On the other hand, the phase voltage V_A will be clamped to the negative rail when transistor T4 is switch on, and then to the positive rail when transistor T4 is off and D4 is on, if i_A is negative.

The phase currents will be balanced and sinusoidal with a dc offset after the fault because the phase voltages (V_A , V_B , V_C) are balanced with the sinusoidal pwm modulation before and after the fault. The dc offset current in phase A will be equally divided between the phase B and phase C. This conclusion is only valid under the assumption of magnetic linearity and infinite rotor inertia.

3. PROPOSED METHOD

Fig. 2 shows the flowchart of the fault detection scheme proposed. The process can be divided into three main stages: detection, feature extraction and fault identifier.

3.1. Change detection of stator currents

A change in stator current waveform is defined as the instant at which a sudden increase or decrease is observed in the magnitude of the current. DWT detect the change with the aid of a 'sliding data window'. At each time step, the data in the window is fed to the DWT to compute the corresponding DWT coefficients. A change is considered to have occurred in the stator current waveforms if any wavelet coefficient exceeds or falls below a given band. On detecting the current waveform change, the sliding data window aligns itself to the point when the change was detected.

3.2. Feature extraction

The feature extraction process is introduced to enhance the difference in the currents change profile between the transistor base drive open-circuit fault and other faults or disturbances such as intermittent misfiring of inverter switching device, single line to ground at machine terminal and load disturbance. The process takes place only after a change is detected in the stator current waveforms.

On detecting the change, the system will determine the dc offset in the sliding window of stator currents. Then, the system will wait for 4 current cycles before checking the dc offset for the second time. The transistor base drive open-circuit fault is considered to have happened if the dc offset is existing in the stator currents. However, if the dc offset disappeared in the later event, the intermittent misfiring is considered to have happened since the currents take 2 to 4 cycles to get back to normal operating condition, depending on drive controller type [8].

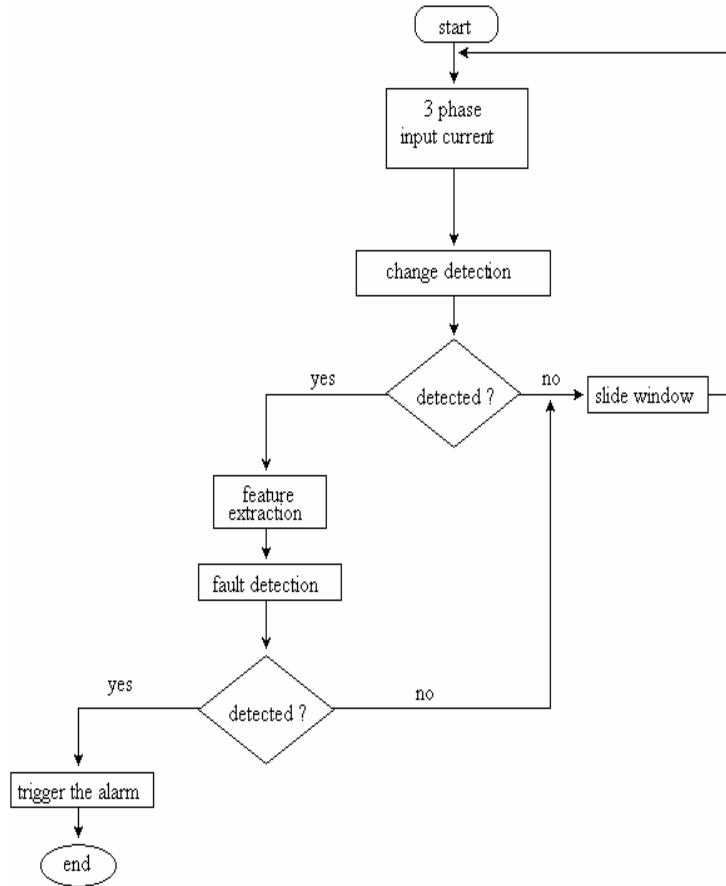

Fig. 2: Flowchart of fault detection method

3.3. Fault identifier

An artificial intelligent system such as fuzzy is recommended to be used to identify the faulty device, as classified in Table 1.

Table 1: Fault identifier

Faulty Device	Dc Current Offset Polarity		
	Phase A	Phase B	Phase C
T1	negative	positive	positive
T2	negative	negative	positive
T3	positive	negative	positive
T4	positive	negative	negative
T5	positive	positive	negative
T6	negative	positive	negative

4. EXPERIMENTAL RESULTS

The motor used in this experiment is a 3-phase, 50 Hz, 3 hp, 4 pole, squirrel cage induction motor. The PWM waveform waveforms and the fuzzy controller are performed on a single chip Intel 80C196KC 16-bit micro controller. The motor shaft is coupled with a dc generator. The drive system was initially tested under the normal operation mode. The speed was kept constant at 1000 rpm with 100 Vdc supply. Fig.3 shows the stator current waveforms for normal operation. Then, the base drive open circuit fault (F1) is introduced and stator currents are examined as a function of failure mode. Fig. 4 to fig. 9 shows six different stator currents corresponding to the individual transistor base drive open-circuit fault of T1, T2, T3, T4, T5 and T6. It can be seen that, in all six cases, this fault introduces a non-zero dc offset.

In the detection process, DWT was implemented using Daubenchies 1 (db1) function as the "mother" wavelet. The occurrence of a current change is characterised by a sharp surge or overshoot in the value of a coefficient, as can be seen clearly in fig. 4(b) to fig.9(b). This is one of the features that wavelet transform has, as described before.

In this experiment, it was decided that if the magnitude of the wavelet coefficient at decomposition level $m = 1$ is overshoot beyond 0.03 or undershoot below -0.03 , a change is considered to have occurred. This band was chosen after confirming that the level 1 coefficient does not exceed this value during steady-state operation of the induction motor (the band may be increased or decreased depend on the value of operating stator currents).

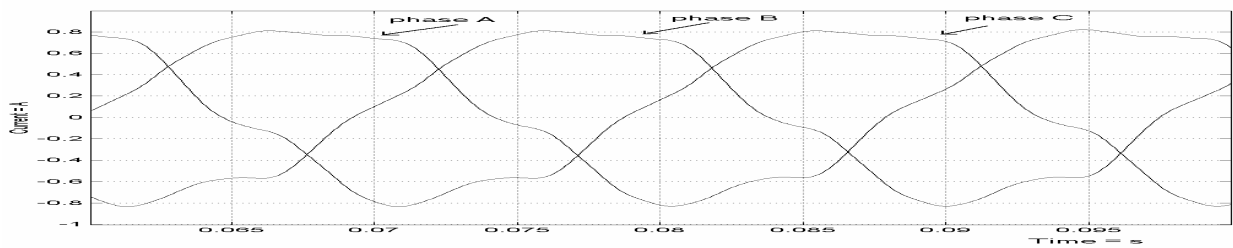

Fig. 3: Stator current waveforms for normal condition

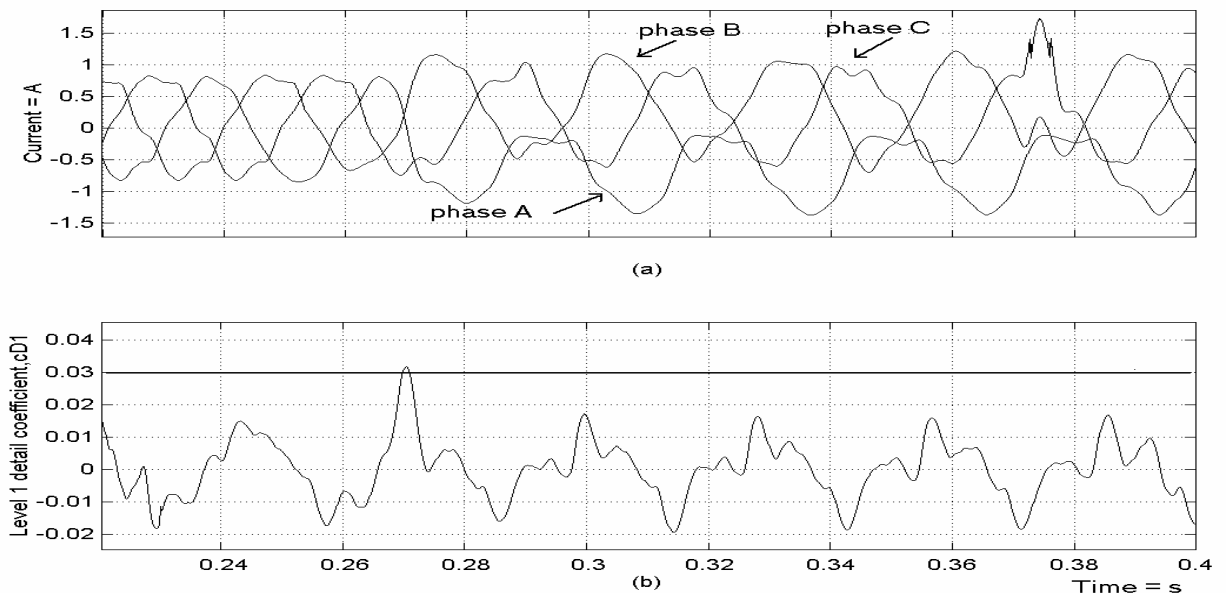

Fig. 4: Transistor T1 open-circuit fault: (a) 3-phase stator current waveforms ,
(b) level 1 detail coefficient of phase A stator current.

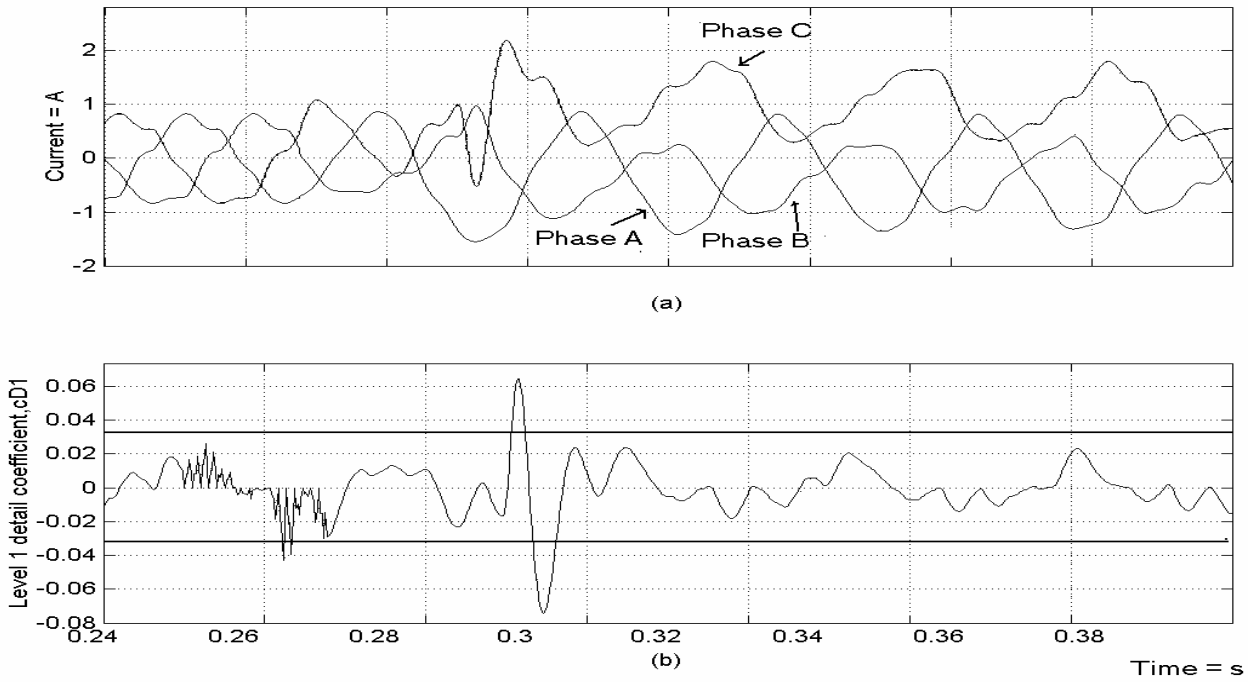

Fig. 5: Transistor T2 open-circuit fault: (a) 3-phase stator current waveforms , (b) level 1 detail coefficient of phase C stator current.

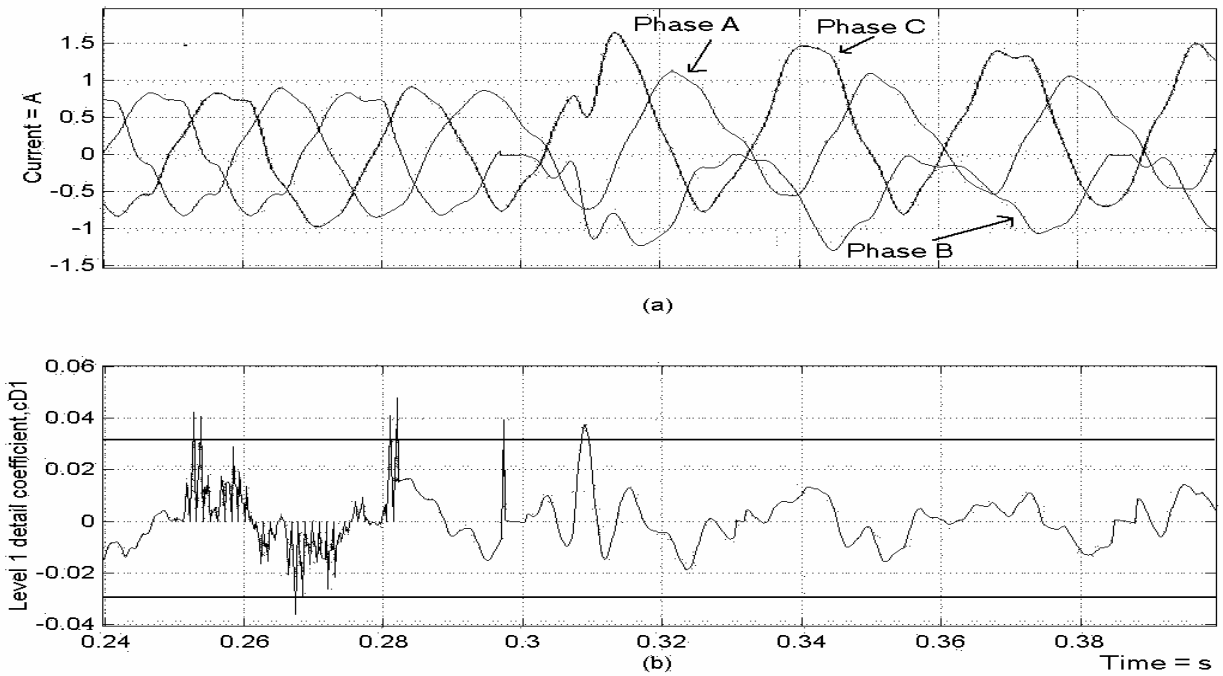

Fig. 6: Transistor T3 open-circuit fault: (a) 3-phase stator current waveforms , (b) level 1 detail coefficient of phase B stator current.

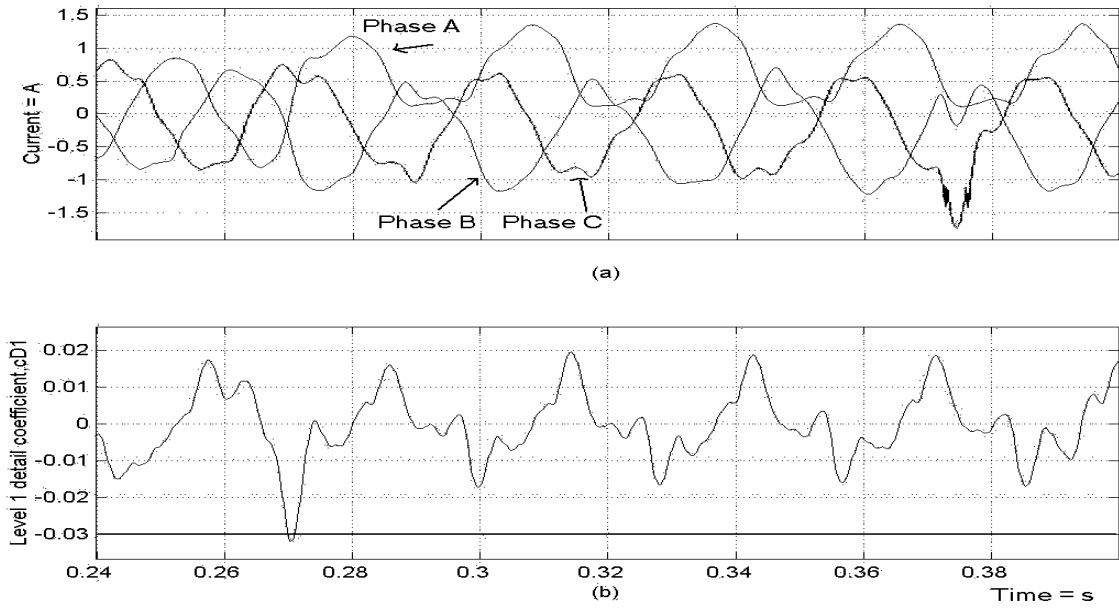

Fig.7: Transistor T4 open-circuit fault: (a) 3-phase stator current waveforms ,
(b) level 1 detail coefficient of phase A stator current.

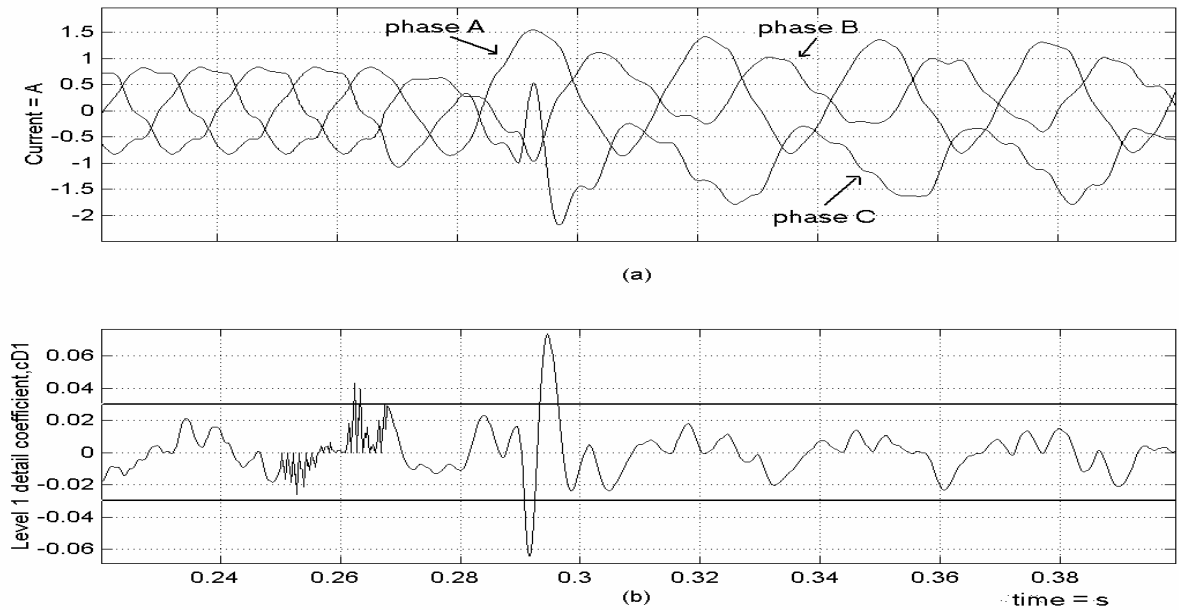

Fig. 8: Transistor T5 open-circuit fault: (a) 3-phase stator current waveforms ,
(b) level 1 detail coefficient of phase C stator current.

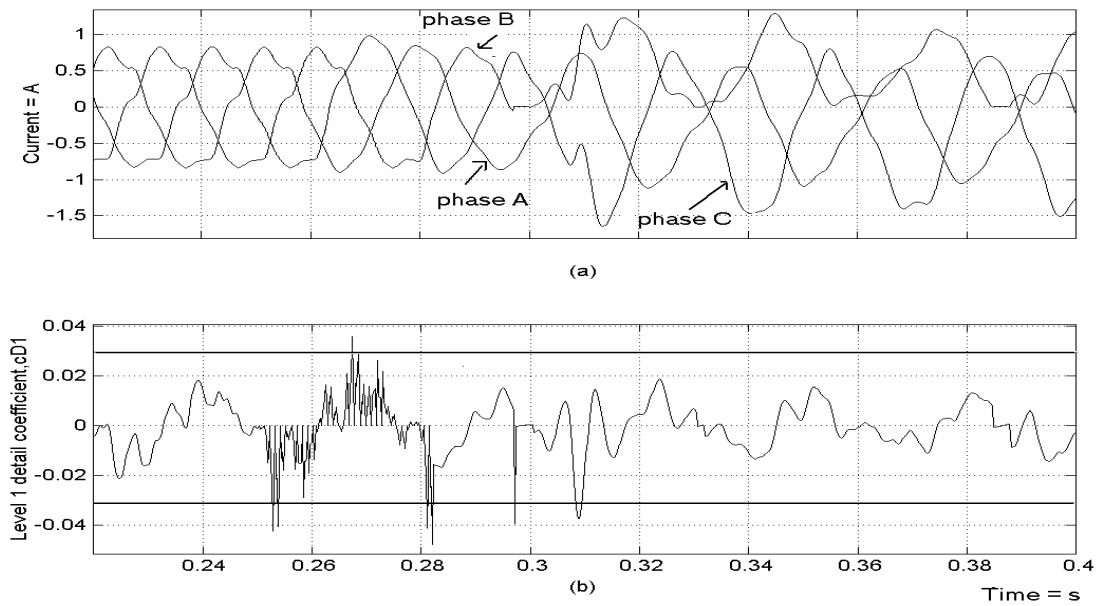

Fig. 9: Transistor T6 open-circuit fault: (a) 3-phase stator current waveforms ,
(b) level 1 detail coefficient of phase B stator current.

5. CONCLUSION

This paper presents systematically the novel approach to detect the inverter faults of closed loop fuzzy controlled induction motor. The wavelet transform of stator currents has been used to identify the inverter faults. The results are extremely important for the monitoring and fault detection of the inverter in drives system. The work can be extended to other converter configurations or drives with other type closed loop controller.

NOMENCLATURE

i_A	: Phase A current	Ampere
V_A	: Phase A voltage	Volt
DWT	: Discrete wavelet transform	
cD1	: Wavelet detail coefficient	
db1	: Daubechies 1	
m	: Wavelet decomposition level	

REFERENCES

- [1] J. R. Cameron, W. T. Thomson and A. D. Dow, "Vibration and Current Monitoring for Detecting Airgap Eccentricity In Large Induction Motors", *I.E.E Proceeding*, **133**, B, 155-163, 1986.
- [2] C. Hargis, B. G. Gaydon and K. Kamash, "The Detection of Rotor Defects in Induction Motors", *Proceedings of International Conference on Electrical Machine-Design and Application*, **213**, 216-220, 1988.
- [3] J. Penman, M. N. Dey, A. J. Tait and W. E. Bryan, "Condition Monitoring of Electrical Drives", *IEE Proceedings*, **133**, B, 65-69, 1986.
- [4] A. C. Renfrew and J. X. Tian, "Fault Diagnosis in Power Electronic Converter", *Proceeding of Universities Power Engineering Conference*, 565-568, 1993.
- [5] I. B. Aris, L. Zhang and L. N. Hulley, "Fault Detection of an Inverter Circuit by Digital Signal Processing and Knowledge Based Approach", *Proceeding of Universities Power Engineering Conference*, 489-491, 1994.
- [6] D. Kastha and B. K. Bose, "Investigation of Fault Modes of Voltage-Fed Inverter System for Induction Motor Drive", *IEEE Transactions on Industry Applications*, **30**, 1028-1037, 1994.
- [7] A. M. S. Mendes, A. J. M. Cardodo and E. S. Saraiva, "Voltage Source Inverter Fault Diagnosis in Variable Speed ac Drives, by Park's Vector Approach", *Proceeding of 7th. International Conference on Power Electronics and Variable Speed Drives*, 538-543, 1998.
- [8] Scot Smith Kenneth, Li Ran and Jim Penman, "Real-time Detection of Intermittent Misfiring in a Voltage-Fed PWM Inverter Induction-Motor Drive", *IEEE Transactions on Industrial Electronics*, vol.44, no. 4, pp. 468-476, August 1997